

FLOOR INSTALLATION GUIDE

IMPORTANT!

To avoid any color variation, it is strongly advised to install panels from the same production batch for the entire project. Always verify the batch number printed on each package before beginning the installation.

IMPORTANT!

Before starting the installation, all panels must be thoroughly inspected for any defects, including surface imperfections, damage to the locking system, and inconsistencies in color or gloss.

Natural features such as varied textures, grain patterns, knots, lighter wood rings, or cracks are intentional design elements and are not considered product flaws. Installing the panels is treated as acceptance of their condition; therefore, any claims regarding color, surface, or design differences after installation will not be accepted.

It is advised to pre-sort panels by tone and pattern before laying them. Alternate different shades and patterns during installation to achieve a balanced and natural appearance. For the best visual outcome, install panels in the direction of the primary light source.

Once a package is opened, its contents should be used immediately (see - PREPARATION, section 11).

PREPARATION CONDITIONS:

Room temperature should be maintained between 18°C and 30°C, with relative humidity kept within the range of 40% to 65%.

1. If the product was transported at temperatures above 5°C, allow it to acclimate for at least 24 hours in a room

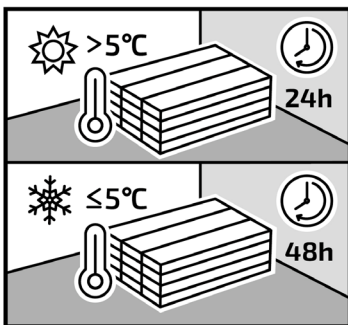

maintained at 18–30°C.

If transported at or below 5°C, extend the acclimatization period to a minimum of 48 hours under the same indoor conditions.

2. Switch off underfloor heating at least 24 hours prior to installation.

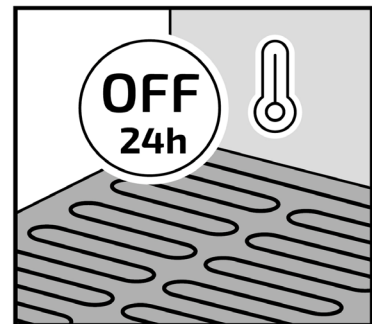

3. The condition and preparation of the subfloor—particularly its flatness and stability—are critical to achieving a successful installation outcome.

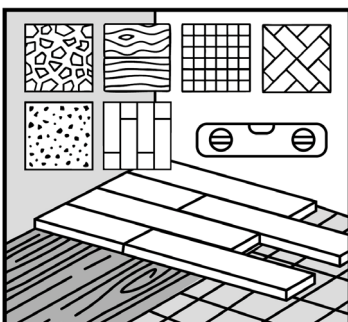

These panels can be installed over cement or anhydrite screeds, self-leveling compounds, ceramic tile surfaces, as well as OSB or plywood boards, provided they are rigid, stable, and have a moisture content below 8-10%.

Do not install panels directly over carpets or soft floor coverings.

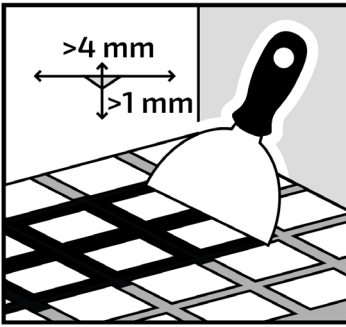

4. When installing over ceramic tile surfaces, joints wider than 4 mm and deeper than 1 mm must be filled with a durable repair compound, such as a resin-based grout.

Installation without additional leveling is acceptable if tile joints are no wider than 5 mm and no deeper than 1 mm.

For best results, always fill visible grout lines and apply a primer across the entire tiled surface before proceeding with installation.

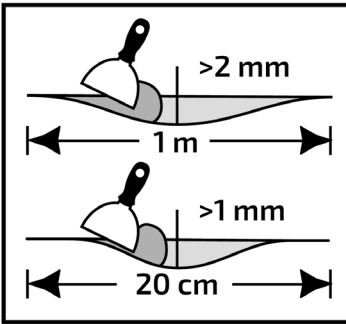

5. Ensure the subfloor is perfectly level. Any uneven areas greater than 1 mm over 20 cm or 2 mm over 1 meter must be corrected.

Assess whether a primer or sealing agent is required for the surface. For optimal preparation, apply a suitable grout or a self-leveling compound across the entire area.

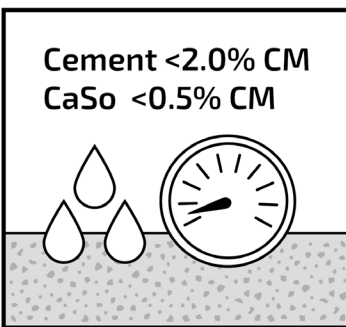

6. For cement-based screeds, the moisture content must be below 2.0%, and for anhydrite screeds, it must be below 0.5%.

When installing over underfloor heating systems, these limits are stricter — moisture must not exceed 1.8% for cement screeds and 0.3% for anhydrite screeds.

7.8. Floor panels can be installed over underfloor heating systems as long as the surface temperature does not exceed 27°C.

The heating system must be turned off at least 24 hours prior to installation. After the panels are installed, wait another 24 hours before gradually turning the heating back on—increase the temperature by no more than 5°C per day.

Installation is permitted over water-based heating systems or electric systems embedded in the subfloor, provided they stay within the specified temperature limits.

Direct installation over electric, infrared heating systems and heating mats is not recommended.

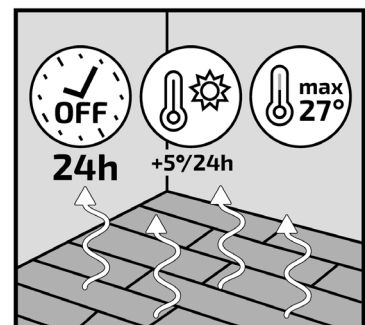
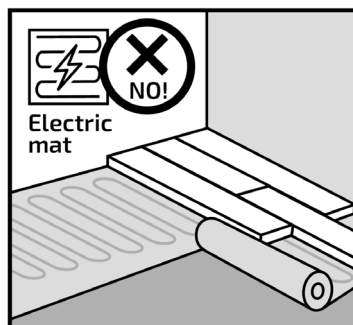
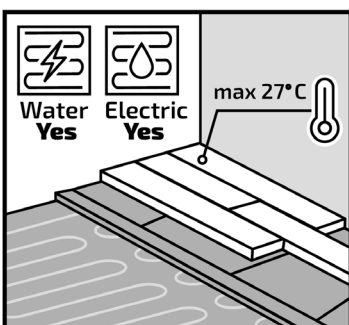

9. Ensure the subfloor is dry, level, stable, and free from grease, oils, or any chemical residues.

Any raised imperfections should be scraped off and eliminated. Before starting the installation, thoroughly

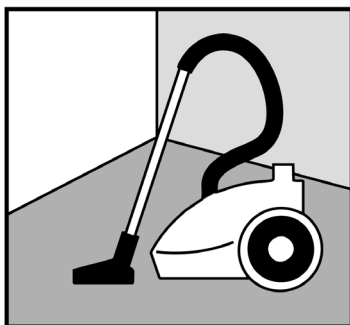

sweep and vacuum the entire surface to remove all dust and debris.

Significant surface defects or large cracks must be properly repaired to provide a solid and even foundation.

10. Inspect all panels under proper lighting conditions both before and during installation.

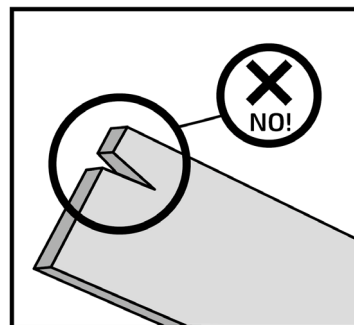

Do not install any panels that show visible defects.

PANEL INSTALLATION CONDITIONS:

Room temperature: 18–30°C

Relative humidity: 40–65%

Subfloor temperature: minimum 15°C

1. Lay the Treasure Lakes, Sky Painted Mercury panels directly onto the prepared subfloor, as they come with an integrated underlay.

Do not use any additional underlay beneath these products. Integrated underlay provides the necessary acoustic and leveling performance, and adding extra layers may compromise the installation and void the warranty.

2. Maintain no less than 5 mm expansion gap along all walls and fixed elements to allow for natural floor movement.

The maximum allowable length of a continuous floor installation is 10 meters, and maximum weight 20 meters. If this limit is exceeded, expansion joints must be introduced, and the expansion gap should be increased to 10 mm. There are no limitations on the maximum installation width.

3. For trimming floor panels, use a sharp utility knife to score the top surface, then snap the panel by applying firm pressure over an edge.

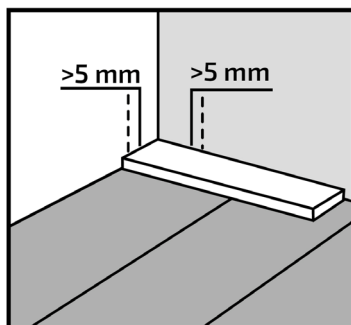
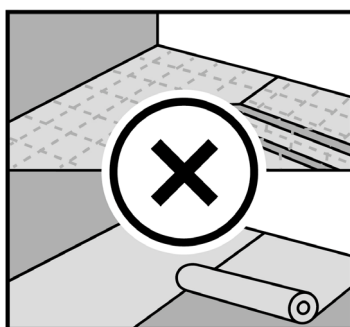
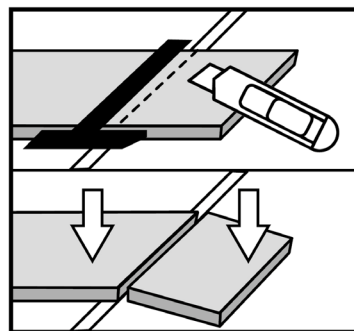

4. The panels are equipped with locking systems on both the long and short sides.

Begin by connecting the long edge—insert it at an angle into the groove of the panel in the previous row. Slide the panel into place, starting from the corner while maintaining a small expansion gap.

5. Next, carefully lower the panel to engage the short-side lock, pressing it down gently with your fingers—starting from the corner and working toward yourself.

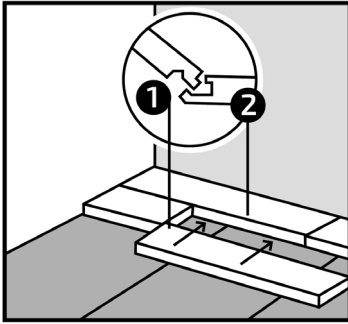

IMPORTANT: Do not apply excessive force.

If the panel doesn't lock easily, slightly adjust the angle or spacing, then try lowering it again.

IMPORTANT!

In each new row, stagger the cross joints by at least 30 cm to ensure stability and a natural look.

Before starting the installation, measure the room carefully to ensure that the panels in the first and last rows will be no narrower than 10 cm. Adjust the layout accordingly if needed.

FLOOR FINISHING CONDITIONS:

Ambient temperature: 18–30°C

Relative humidity: 40–65%

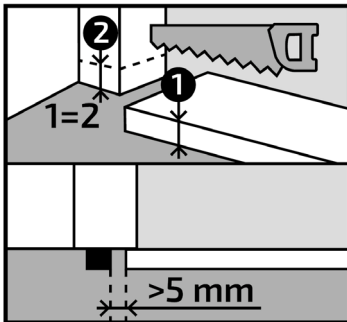

1. Expansion gaps along the perimeter should be covered with decorative skirting boards.

2. At doorways, it is advisable to undercut the door frames to allow the panels to slide underneath, leaving sufficient clearance above the flooring to avoid restricting natural expansion and movement.

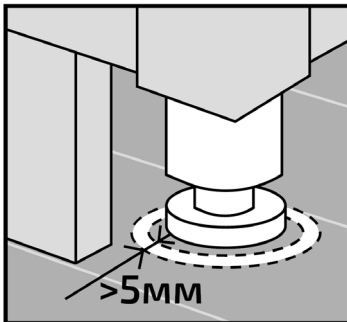

3. For vertical pipes extending from the subfloor, be sure to leave a clearance gap around them. Drill holes that are 5 mm larger in diameter than the pipes themselves to allow for expansion and movement of the flooring.

4. For any heavy items placed on the flooring—such as kitchen cabinets, islands, built-in wardrobes, or other fixed furniture—it is essential to leave a 5 mm expansion gap around their base.

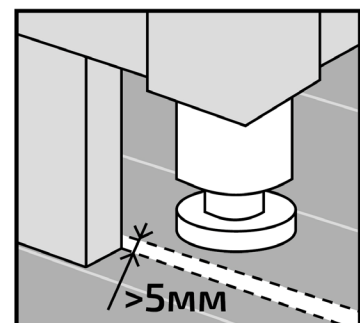
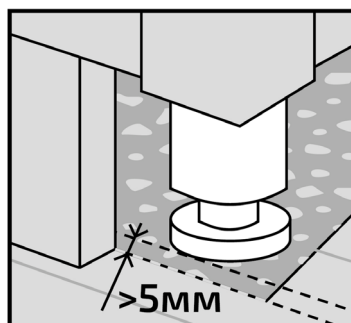
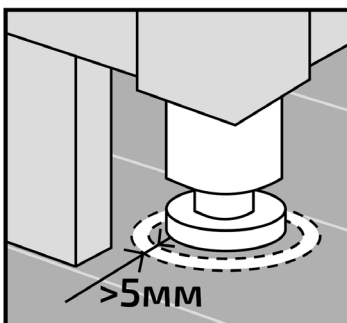

To maintain this gap, consider one of the following methods:

- Option A: Cut leg openings in the panels with an additional 5 mm clearance on all sides.
- Option B: Use a saw to create a 5 mm expansion gap along the edge of the furniture.
- Option C: End the flooring installation at a 5 mm distance from the heavy object on all sides.

USE & MAINTENANCE CONDITIONS:

Room temperature: 18–30°C

Relative humidity: 40–65%

1. The floor can be cleaned using a vacuum cleaner, but the use of steam mops or steam cleaning devices is strictly prohibited.

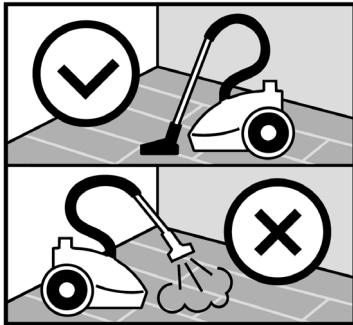

2. The floor may be cleaned using a damp or wet mop, ensuring it is not excessively soaked. Avoid leaving standing water on the surface.



3. Dragging heavy objects across the floor is not permitted. They must be lifted and carried to prevent damage to the surface.

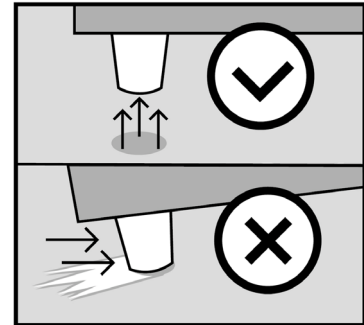

4. Office chairs should be equipped with W-type soft castors to prevent surface wear. Additionally, it's recommended to use a protective mat beneath them.

Furniture legs must have protective pads, such as felt glides, to minimize the risk of scratching the floor.

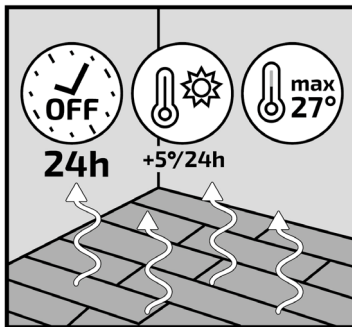
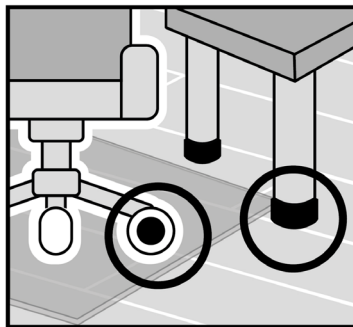

5. Wait 24 hours after the floor has been installed before turning the underfloor heating back on. Increase the temperature gradually, by no more than 5°C per day.

IMPORTANT: The floor surface temperature must not exceed 27°C at any time.